

Visual perception modulated by galvanic vestibular stimulation

Naohisa NAGAYA^{*1}, Maki SUGIMOTO^{*1}, Hideaki NII^{*1},
Michiteru KITAZAKI^{*2} and Masahiko INAMI^{*1,*3}

^{*1}Graduate School of The University of Electro-Communications
1-5-1 Chofugaoka, Chofu-shi, Tokyo 182-8585, JAPAN
{nagaya,sugimoto,nii,inami}@hi.mce.uec.a.jp

^{*2}Research Center for Future Vehicle, Toyohashi University of Technology
1-1 Hibarigaoka, Tempaku-cho, Toyohashi 441-8580, JAPAN.
Tempaku-cho, Toyohashi 441-8580, JAPAN.
mich@tutkie.tut.ac.jp

^{*3}Japan Science and Technology Agency
1-5-1 Chofugaoka, Chofu-shi, Tokyo 182-8585, JAPAN

Abstract

Galvanic vestibular stimulation (GVS) induces a sensation of virtual acceleration as vestibular information and its application is expected as a wearable interface because it does not need a large device like a motion platform. In particular, GVS with alternating current (AC) can influence vision that mainly consists of a torsional component. This research aimed to quantitatively evaluate the effects of GVS on visual perception, and to infer its cause. To investigate these issues, we conducted psychophysical experiments during GVS with AC that consisted of three different image presentation methods; images fixed on spatial coordinate, head coordinate and retina coordinate systems. It is suggested that the visual motion perception induced by GVS is mediated by eye movements. As well, the stimulus frequency response of the current threshold, at which the subjects perceived visual motion, showed a U-shaped curve for stimulus frequency dependency.

Key words: Galvanic vestibular stimulation, Visual perception, Eye movement, Alternating-current

1. Introduction

In the past, as mechanical techniques to induce vestibular sensations by moving the human body, there have been motion platforms such as the Stewart platform. In comparison with these, the galvanic vestibular stimulation (GVS) system is small and light, and easily constructs the environment. GVS results in stimulation of the vestibular system when a small current (below 3 mA) is passed between the mastoid processes. GVS causes standing subjects to adapt to a new final tilted position relative to gravity after an initial sway response towards the anodal ear and to feel virtual

acceleration [1], [2]. Furthermore, GVS has been shown to influence various functions, such as the control posture [3], [4], human walking [5],[6],and eye movements. In particular, eye movement responses induced by GVS consist mainly of torsional and horizontal components [7].The ocular torsion-related effects of constant GVS with tolerable currents are similar to an accelerated head rotation at small amplitudes, which stimulates all semicircular canal afferents [8]. The amount of the displacement of eye movement depends on the stimulus current value [7], [9].

There have also been many studies where GVS has been used as an acceleration interface. "Radio-controlled walking" is an attempt to mimic human walking using GVS-induced vestibular information [10]. "Motionware" [14] and "Virtual Acceleration on Race Game" [15] produces a sense of motion during video games such as car racing games . However, most recent studies have used direct or alternating currents of a frequency less than 1 Hz as the stimulation for GVS. However, the characteristics of the phenomenon caused by frequency stimulation higher than 1Hz are not well known.

"Electric Dance Revolution", which was developed by the authors, is a system that allows subjects to experience vestibular sensation by means of GVS synchronized with music rhythms [11]. This was aided by the fact that the authors had noticed that GVS with alternating current can induce visual motion perception.

In this paper, we investigated the cause, and frequency response, of influences on vision during GVS in a wide stimulation frequency band to 32 Hz from a low frequency of less than 1 Hz, and then quantitatively evaluate the effects of GVS on visual perception and infer its cause.

2. Methods

2.1 Visual motion induced by GVS

Visual motion is perceived as a rotation movement that centers on the central point of the view of the subject for whom the world was originally perceived as stable; shown in Figure 1 with GVS that uses an AC.



Fig.1 Example of a visual effect image

It is possible to bring the motion together utilizing three factors by assuming that this phenomenon is caused by GVS.

- (1) The image moves by a shake of the head caused by GVS and it is then perceived.
- (2) The image moves by ocular torsion caused by GVS and it is then perceived.
- (3) GVS has some influences on the brain and it is then perceived.

In this experiment, three experimental conditions were set to verify whether the influence on vision invited by GVS with AC was caused by any of these three factors.

2.2 Subject preparation

Five healthy subjects (males aged 21-34 years) gave their informed consent to participate in the study after being briefed about the experience. None of the subjects had any history of visual or vestibular disorders.

2.3 Galvanic stimulation

Gel-electrodes (National, Japan) were attached over each mastoid process and stabilized with tape (Figure 2). The skin behind the ears was rubbed with alcohol to decrease impedance.

A galvanic stimulus unit used a current mirror circuit as a constant current circuit and realized a stable stimulation with high safety to the subject. It provided an output current of ± 2.5 mA and was equipped with a MPU: Micro- Processing Unit (PIC18F252, Microchip Technology Inc, Arizona, USA) as the processing device for wave pattern control. The MPU had 256 phases of

resolving power (the smallest resolving power was 0.02 mA) to send out the input value to a DA converter by serial communication of 8 bits. An H bridge circuit in an output edge was used to select the polarity of an electrode with a single power supply.



Fig.2 Electrodes applied to a subject

2.4 Experimental protocol

Three different types of experiment to measure the current threshold that produced visual motion perception induced by GVS were performed with each subject in a darkroom. These thresholds were measured by the up-and-down method. Stimulations with different amounts of current were presented to the subject at each stimulation frequency, who was made to answer by two methods whether it was perceived as the presentation image having moved.

The three types of experiment were

- (1) Image fixed on a spatial coordinate system
- (2) Image fixed on a head coordinate system
- (3) Image fixed on a retina coordinate system

Furthermore, because of our within-subjects design; we eliminated any order effect by using the following procedure in each of these experiments. We set the sequence of experiments with each subject at random and every time instructed subjects at the beginning and end of each stimulation.

2.4.1 Experiment 1

Subjects were instructed to sit on a chair 2.0 m from a wall surface in a darkroom and to look fixedly at the center of the line ahead. The stimulation time was set at 5 seconds and adjusted by the stimulation frequency. In this experiment, the stimulation frequencies were 0.10, 0.25, 0.50, 0.75, 1.0, 2.0, 4.0, 6.0, 8.0, 12, 16 and 32 Hz, and the stimulation current amplitudes were 0.02-2.0 mA.

The experimental set-up was as follows (Fig 3): the

image presentation method used a red-laser pointer (RX-5, Sakuracraypas, Japan) which could display a line rather than a point, and the size of the image was calibrated with a 20° viewing angle (a length of about 0.70 m).

Four conditions were collected combining two image conditions (horizontal line and vertical line), and two head fixation conditions (chin rest used or not used).

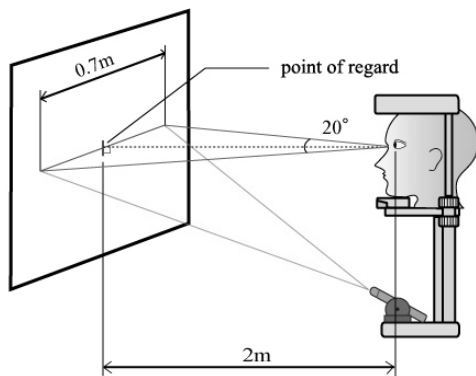

Fig.3 Experimental set-up (Experiment 1)

2.4.2 Experiment 2

In the second experiment, to fix an image on a head coordinate system, all data could be measured without the influence of relative movement, by rolling the head.

The experimental set-up was as follows (Fig 4): the method of presenting each image used a HMD: Head Mounted Display (PUD-J5A, SONY, Japan) which carried two 0.44 inch 1.8 million-pixel LCDs attached to over-the-head type headphones. These displays gave the subject a sense of watching a 42-inch screen at a distance of 2.0 m.

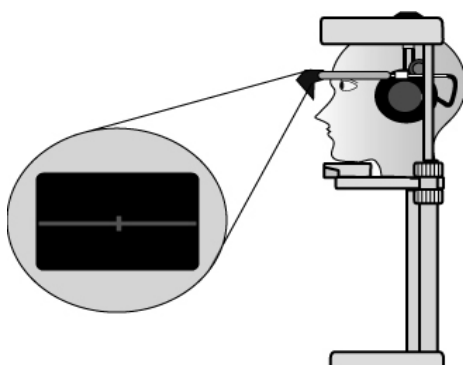

Fig.4 Experimental set-up (Experiment 2)

The stimulation frequency, stimulation current amplitudes and measuring method were the same as in experiment 1. However the presentation image was only the horizon and there were two head-fixation conditions

(chin rest used or not used). The size of the image was 720 pixels by 534 pixels, and its resolution was 72 pixels/inch.

2.4.3 Experiment 3

In experiment 3, to fix an image on a retina coordinate system, all data could be measured without the influence of eye movements induced by GVS.

The experimental set-up was as follows: as the image presentation method, a retina afterimage with a tan incandescence ball that followed a slit was used. An example of the image is shown in Figure 5. The stimulation frequencies were 1.0, 2.0, 12 and 32 Hz. The measuring method was the same as in experiment 1.

Data from four conditions were collected combining two image conditions (horizontal line and vertical line), and two head fixation conditions (chin rest used or not used).



Fig.5 Example of an image (horizontal line)

3. Results

3.1 Stimulus frequency responses of the current threshold

Figures 6 and 7 show graphs of the frequency responses of the current threshold provided in each experiment. The horizontal axis is the stimulation frequency and the vertical axis the current threshold for motion perception for a line, to the stimulation frequency. A-E in each graph denotes the five subjects (subjects A-E: ages 21, 23, 23, 25, and 34 years old respectively).

When a subject reported that they could not perceive the image motion with the application of the maximum stimulus current (2 mA), we considered that effective data were not measurable and plotted to 2.0 mA in a graph.

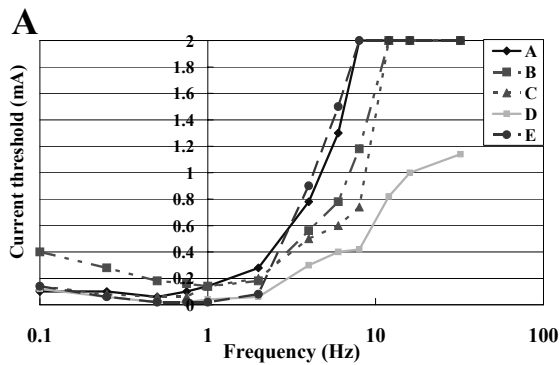

Horizontal visual line and Chin rest use

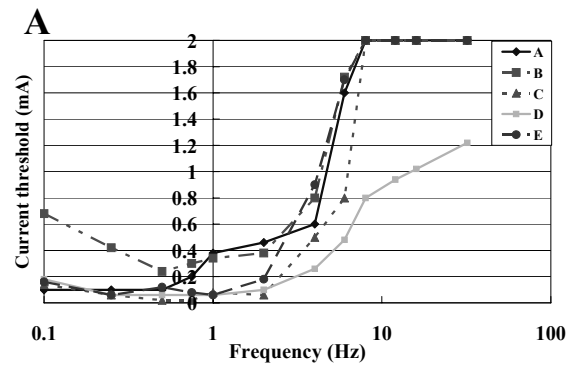

HMD and Chin rest use

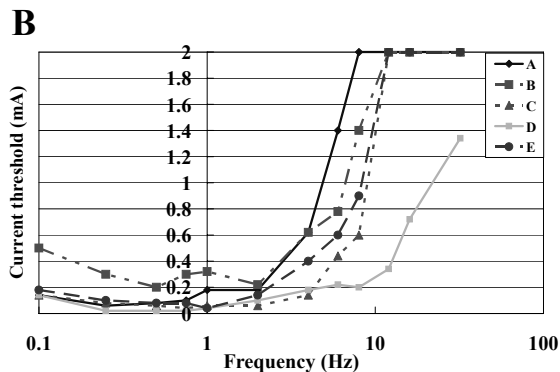

Horizontal visual line and Chin rest non-use

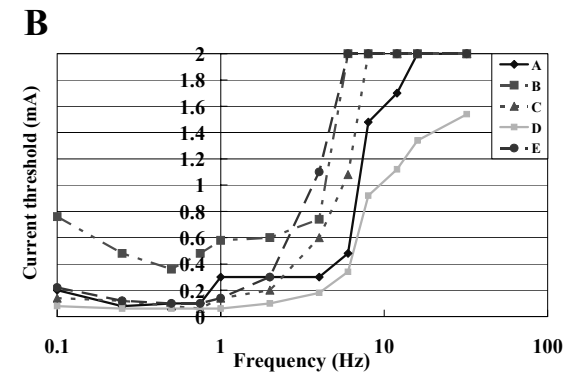

HMD and Chin rest non-use

Fig. 7 Frequency response (Experiment 2)

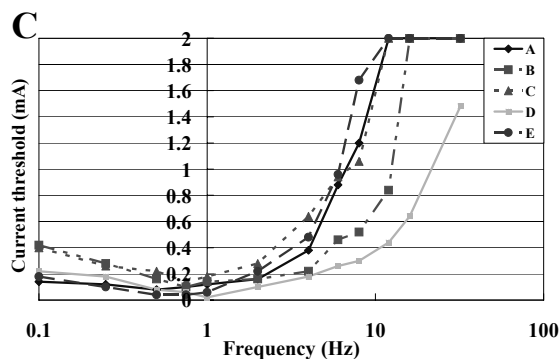

Vertical visual line and Chin rest use

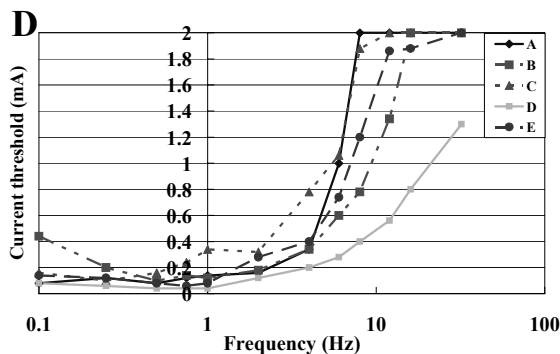

Vertical visual line and Chin rest non-use

Fig. 6 Frequency response (Experiment 1)

3.1.1 Experiment 1

Figure 6 shows measurement data from experiment 1. The current threshold became the smallest when the frequency was between 0.75 and 1.0 Hz for all conditions, a finding that is reflected by the U-shaped curve for the stimulus frequency. In other words it was easy to perceive the visual motion when the frequency was in the range of 0.75-1.0 Hz.

During the presentation of a horizontal line, all subjects mainly perceived horizon-rotary motion in a roll direction around the fixation point. At less than 1.0 Hz, all subjects felt the frequency of rotation synchronized to the frequency of head-rotation. At 0.10 Hz all subjects felt a very slow rotation. However, from 4.0 Hz or more, all subjects felt the visual motion as vibration in the horizontal direction. At 6.0 Hz, when the current value became greater than a certain value, four subjects (subjects A, B, C and E) felt that their peripheral field blinked on and off. At 8.0 Hz, subject D felt this blink, too. The brightness and frequency of this phenomenon could be increased by increasing the value of the stimulus current and frequency. However, even at 32 Hz, two subjects (subject D and E) did not feel it.

Table 1. ANOVA table (Subjects \times Coordination system \times Head fixation \times Stimulus frequency)

Factor	SS	df	MS(SS/df)	F
Subject (S)	10.323	4	2.581	
Coordination system (A)	1.168	1	1.168	7.64*
S \times A	0.612	4	0.153	
Head fixation (B)	0.030	1	0.030	0.52ns
S \times B	0.231	4	0.058	
Stimulus frequency (C)	120.111	11	10.919	55.03***
S \times C	8.731	44	0.198	
A \times B	0.077	1	0.077	0.87ns
S \times A \times B	0.353	4	0.088	
B \times C	0.357	11	0.032	2.67**
S \times B \times C	0.534	44	0.012	
A \times C	1.634	11	0.149	2.51**
S \times A \times C	2.604	44	0.059	
A \times B \times C	0.067	11	0.006	0.22ns
S \times A \times B \times C	1.185	44	0.027	

Table 2 ANOVA table (Subjects \times Line orientation \times Head fixation \times Stimulus frequency)

Factor	SS	df	MS(SS/df)	F
Subject (S)	8.614	4	2.154	
Line orientation (A)	0.034	1	0.034	0.12ns
S \times A	1.133	4	0.283	
Head fixation (B)	0.013	1	0.013	0.17ns
S \times B	0.292	4	0.073	
Stimulus frequency (C)	108.816	11	9.892	38.72***
S \times C	11.242	44	0.255	
A \times B	0.115	1	0.115	15.20**
S \times A \times B	0.030	4	0.008	
B \times C	0.104	11	0.009	0.35ns
S \times B \times C	1.186	44	0.027	
A \times C	0.329	11	0.030	0.77ns
S \times A \times C	1.703	44	0.039	
A \times B \times C	0.515	11	0.047	4.61***
S \times A \times B \times C	0.446	44	0.010	

ns $p > .10$; * $p < .10$; ** $p < .05$; *** $p < .01$

SS; sum of square, df; degree of freedom, MS; mean square

During the presentation of a vertical line, the visual motion was one of rotation, although some subjects felt that the center of rotation was under the point of visual fixation. Other phenomena were similar to those in the case of the horizon.

3.1.2 Experiment 2

Figure 7 shows measurement data from experiment 2. The shape of the graph is similar to that of experiment 1. However, subject B had a lower perception of the visual motion and visual perception depended on the stimulus frequency similar to the condition of the horizon in experiment 1; blinking on and off of the peripheral vision was also confirmed.

3.1.3 Experiment 3

In experiment 3, no subjects perceived any visual motion of the presented image. However, all subjects answered that they had perceived blinking in the peripheral field as in experiment 1 and 2 at 12 and 32Hz of stimulation frequency.

3.2 Data analysis

Two kinds of a three-way repeated measures ANOVA (analysis of variance) were used to test the main effects of the independent variables. One related the head fixation condition (chin rest used or not used), coordinate system (spatial and head), and stimulus frequencies (0.10-32 Hz). The other related the head

fixation condition (chin rest used or not used), line-orientation condition (horizontal and vertical), and stimulus frequencies (0.10-32 Hz).

The results of three-way repeated measures ANOVAs are shown in Tables 1 and 2, and show a significant main effect of stimulation frequencies for current threshold [$F(11, 44) = 55.03, P < 0.0001, F(11, 44) = 38.72, P < 0.0001$] and no effect for head fixation condition [$F(1, 4) = 0.52, F(1, 4) = 0.17$].

Table 1. shows that the test just failed to reach statistical significance for the coordinate system [$F(1, 4) = 7.64, P = 0.0507$]. The mean threshold for spatial (= 0.71) was smaller than for head (= 0.85). The tendency it is shown to become difficult for visual motion to be perceived when the image was fixed to the head coordinate system with HMD. Therefore, Table 1. shows two significant interactions; one between the coordination system and the stimulation frequency conditions [$F(11,44) = 2.51, P < 0.05$], and another between the head fixation and stimulation frequency conditions [$F(11,44) = 2.67, P < 0.05$]. This means the characteristic of the frequency dependency of visual motion perception is different depending on either the fixed coordinate system or the head fixation condition in the image. Indeed, when the image is fixed to the head with a HMD, the mean value of the current threshold rises when the image is fixed to the space coordinate system in all the stimulation frequencies and the frequency dependency becomes weak. Concretely, the mean value of the current threshold within the image is fixed to the head with HMD higher than that when the image is fixed to the space coordinate system in all the stimulation frequencies, and the frequency dependency becomes weak.

Table 2. shows a significant interaction between the line orientation and the head fixation conditions [$F(1, 4) = 15.20, P < 0.05$]. The mean threshold for the horizontal-used condition (= 0.74) was higher than that for the horizontal-not used condition (= 0.68). The mean threshold for the vertical-used condition (= 0.67) was smaller than that for the vertical-not used condition (= 0.70). That is, the horizontal line within the chinrest used came to be difficultly for perceiving motion; contrarily the vertical line became easy. Though the interaction of the three factors was also significant [$F(11,44) = 4.61, P < 0.01$], the clear trend was not to be able to be read from the graph.

4. Discussion

There was big difference between the results of experiment 3 and those of experiments 1 and 2. In experiment 3, all data could be measured without the influence of eye movement, but could not in the others. This fact suggested that the visual motion perception induced by GVS is mediated by eye movements.

Furthermore, the result showed that all subjects perceived rotary motion in both the horizontal line and the vertical line. As reported in previous studies, GVS induced torsional and horizontal eye movement, especially torsional eye movement mainly measured during fixation on a stationary target [7]. If these results are true, visual motion would be caused by torsional eye movement by GVS.

It was shown that there was frequency dependency in the visual motion perception induced by GVS with AC from the result of ANOVA. Sensitivity of what is perceived was highest at about 1.0Hz; visual motion was perceived easily, but sensitivity fell rapidly at frequencies higher than 1.0Hz, and the sensitivity decrease was seen a little, as for lower than 1.0 Hz. As a result, it is thought that all the graphs of the obtained frequency responses showed a U-shaped character type for which the minimum value is the current threshold of 0.75-1.0Hz.

Our results showed the effects of the conditions of head fixation and line-orientation on current thresholds that produced a perception of visual motion. However, the effect did not take the same form in all subjects and for all stimulus frequencies. For inter-individuals, eye movement responses to GVS are known to show large inter-individual variability but intra-individual reliability [3], [4], [5], [12], [13]. Figures 6 and 7 show subject D alone perceived motion at a stimulation frequency of 32Hz in all conditions. On the other hand, with respect to stimulus frequencies, specific frequencies (0.10, 4.0 and 6.0 Hz) mainly influenced current threshold values. This means that at 0.10 Hz all subjects felt very slow rotation, and at 4.0 and 6.0 Hz all subjects felt very fast rotation or vibration (not rotation). This might have been being due to several factors, such as body-sway induced by GVS.

Blinking on and off in the peripheral field was shown in all experiments, 1-3. This phenomenon was perceived by all subjects. When it became difficult for the motion of the image, such as rotary motion, to be quickly perceived in accord with the stimulation frequency at which blinking was perceived, the frequency was raised and many subjects did not perceive motion of the image even with the maximum stimulation current value 2.0mA. On the one hand, subject D who had reported on perception of the images movement up to the highest frequency responded that blinking had not been felt at the frequency at which the other four subjects had felt it. It is suggested that there is a correlation between the maximum stimulation frequencies at which visual motion is perceived and that at which blinking is begun to be seen.

5. Conclusions

This study investigated the cause of and the frequency response to influences on visual motion during GVS with AC. The results confirm that torsional eye

movement by GVS induced visual motion. Furthermore, the current threshold at which visual motion is perceived depends greatly on the stimulation frequency, and the current threshold became smallest at frequencies between 0.75 and 1.0 Hz in all conditions, a finding that is reflected by the U-shaped curve for the stimulus frequency dependency. Especially, it is suggested that there is a correlation between the maximum stimulation frequency at which visual motion is perceived and the blinking on and off perceived in the peripheral field. Verifying this correlation by psychology physics experiments remains an issue to be resolved.

Electric Dance Revolution described in paragraph 1 is considered to be based on this result. With this system, it is easy to obtain the visual motion of the rotation that synchronizes with music, because the stimulation frequency used is about 1.0Hz. That is, it can be said that the Electric Dance Revolution is a system that can experience music not only by the vestibular sensation induced by GVS synchronized with music rhythms and the sense of hearing, but also visually as passed on by the visual stimulation that synchronizes with the rhythm. In the future, we want to investigate applications using GVS for portable music terminal units by improving the system by which music is experienced using visuals and the sense of vestibular, and by making the best use of wearable units that are a feature of vestibular sense presentation devices with GVS.

References

- [1] Day BL, Severac Cauquil A, Bartolomei L, et al, " Human body-segment tilts induced by galvanic stimulation: a vestibularly driven balance protection mechanism," *J. Physiol.* 500.3, pp.661-672, May. 1997.
- [2] Tardy-Gervet MF, Severac-Cauquil A, " Effect of galvanic vestibular stimulation on perception of subjective vertical in standing humans," *Percept Mot Skills.* 86 (3 Pt 2), pp. 1155-1161, Jun. 1998.
- [3] Daniel L. Wardman, Brian L. Day and Richard C. Fitzpatrick, " Position and velocity responses to galvanic vestibular stimulation in human subjects during standing," *J. Physiol.* 547.1, pp.293-299, Dec. 2003.
- [4] Daniel L. Wardman, et al, " Effects of galvanic vestibular stimulation on human posture and perception while standing," *J. Physiol.* 551.3, pp.1033-1042, July. 2003.
- [5] Richard C. Fitzpatrick, Daniel L. Wardman and Janet L. Taylor, " Effects of galvanic vestibular stimulation during human walking," *J.Physiol.* 517.3, pp.931-939, Jun. 1999.
- [6] Bent LR, McFadyen BJ, et al, " Magnitude effects of galvanic vestibular stimulation on the trajectory of human gait," *Neurosci Lett.* 279.3, pp.157-160, Feb.2000.
- [7] Klaus Jahn, Andrea Naeßl, Erich Schneider, Michael Strupp, Thomas Brandt, and Marianne Dieterich, " Inverse U-shaped curve for age dependency of torsional eye movement responses to galvanic vestibular stimulation," *Brain.* 126, pp.1579-1589, April. 2003.
- [8] Erich Schneider, Stefan Glasauer, Marianne Dieterich, " Comparison of Human Ocular Torsion Patterns During Natural and Galvanic Vestibular Stimulation," *J. Neurophysiol.* 87, pp.2064-2073, April. 2002.
- [9] Watson SR, Brizuela AE, et al, " Maintained ocular torsion produced by bilateral and unilateral galvanic (DC) vestibular stimulation in humans," *Exp Brain Res.* 122, pp.453-448, Oct. 1998.
- [10] Maki. S, Junji. W, Hideyuki. A, Taro. M, " Inducement of walking direction using vestibular stimulation-The Study of Parasitic Humanoid (XVII)-," *Virtual Reality Society of Japan.* 8, pp.339-342, Sep. 2003. (In Japanese)
- [11] Maki. S, Nagaya. N, Hideaki. N, Masahiko. I, " Electric Dance Revolution: A music experience with Galvanic Vestibular Stimulation," *Entertainment Computing.* pp.35-38, 2004. (In Japanese)
- [12] Zink R, Bucher SF, Weiss A, et al, " Effects of galvanic vestibular stimulation on otolithic and semicircular canal eye movements and perceived vertical," *Electroencephalogr Clin Neurophysiol.* 107, pp. 200-205, Sep. 1998.
- [13] MacDougall HG, Brizuela AE, Burgess AM, et al. " Between-subject variability and within-subject reliability of the human eye-movement response to bilateral galvanic (DC) vestibular stimulation," *Exp Brain Res.* 144, pp. 69-78, May. 2002.
- [14] Post-gazette.com, <http://www.post-gazette.com/businessnews/19980823games4.asp>
- [15] SIGGRAPH 2005 <http://www.siggraph.org/s2005/main.php?f=confere nce&p=etech&s=etech24>